



## Sand Bag Window™

*See more without sacrificing safety*

The Sand Bag Window (SBW) is designed to dramatically increase visibility at entry control points or patrol points where sand bag or earth-filled bunkers are used. The SBW allows soldiers to observe enemy movements through a transparent armor window and engage combatants through a closeable firing port without sacrificing protection.

With the SBW, traditional sand bag fighting positions take on expanded uses from both a tactical and reconnaissance standpoint. The unit provides personnel with NIJ Level IV Armor-Piercing Resistant protection. Standard size is 34" x 34" and weighs 350 pounds. Custom-sized units are also available.

### Specifications

<b>Product Name:</b>	Sand Bag Window
<b>Description:</b>	Window with gun port for sandbag bunkers
<b>Protection:</b>	Up to NIJ Level IV
<b>Weight:</b>	~ 350 lbs

## A fortified position

The Sand Bag Window is constructed of a durable steel armor frame which supports the transparent armor view window. The entire assembly is powder-coated for durability and corrosion resistance. The cube-shaped unit ships fully assembled on one pallet. It can be implemented quickly within a sand bag or earth-filled wall using machinery or lifted by four field soldiers. Alternatively, the SBW can be used in more permanent walled fortifications by fitting the base armor with anchor brackets.



## Staying on the safe side

Viewports that have been damaged after taking fire or shock from explosives can be replaced in the field from inside the bunker. The process requires two people, no tools and can be completed in less than ten minutes without leaving the safety of the bunker.

The SBW is also equipped with a closable weapon port, providing soldiers with a secure firing position with minimal exposure. During combat situations, troops slide the weapon port's protective cover open to gain firing access and look through the window to identify targets. There is no need to leave the safety of the bunker or extend any parts of the body beyond the protected area to engage targets.



Scale Model

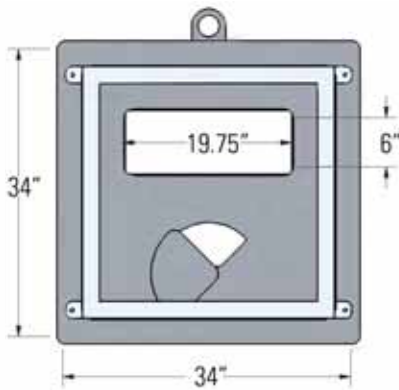

Outside Measurements

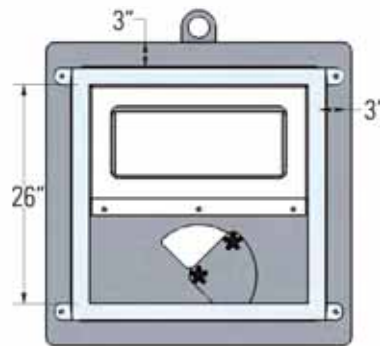

Inside Measurements

## Defenshield, Inc.

Defenshield, Inc. is a veteran-owned, SBA-certified small business manufacturing bullet, blast and fragment resistant equipment for the government, military, law enforcement, and the private sector for anti-terror, force protection, and physical security requirements. Defenshield products are currently saving the lives of a diverse range of customers around the world.

*“Good News for Good Guys”™*



Ballistic data, photographs and video footage are available online at: [www.defenshield.com](http://www.defenshield.com)